



1351 W. Second Street
 Oconomowoc, WI 53066
 Phone: 262-567-2288; 800-434-0062
 Fax: 262-567-0857
 E-mail: sales@ductowire.com

1445 Norjohn Ct. Unit 10
 Burlington, Ontario, Canada L7L 0E6
 Phone: 905-331-2612; 800-361-WIRE (9473)
 Fax: 905-331-6639; 800-663-0933
 E-mail: dow@ductowire.ca

SPECIAL INSTALLATION INSTRUCTIONS SUPPLEMENT DUCT-O-BAR FIGURE 8 SYSTEMS

ENCLOSED FLAP MODEL

Totally enclosed conductors are mounted vertically.

Step 1 — Hanger Clamp Installation

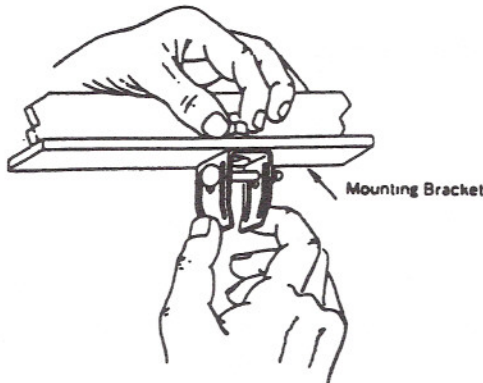

Fasten the hanger clamps on the hanger brackets and leave the mounting and clamping bolts loose.

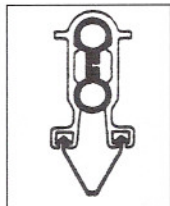

EFE

CAUTION

MAKE CERTAIN POWER SUPPLY IS DISCONNECTED BEFORE INSTALLING, REPAIRING, OR WORKING IN THE PROXIMITY OF ANY ELECTRICAL SYSTEM. ONLY QUALIFIED ELECTRICAL PERSONNEL SHOULD INSTALL OR REPAIR THESE PRODUCTS

Step 2 — Conductor Assembly Installation (Standard Hangers)

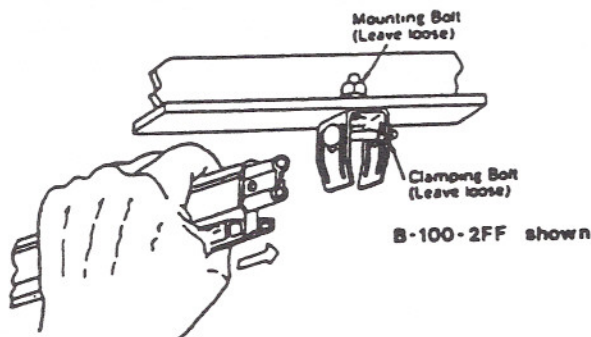

Slide the conductor bar into the hanger clamps. Proceed to Step 3. Start the conductor bar so that the first mounting bracket is 6" from the end.

Minimum conductor spacing is 2" apart with recommended spacing at 3".

Step 3 — Joining Conductor Bar Sections

Joint cover has a short cover piece in the center to provide continuous flap path.



Be sure joint covers are snapped down completely in place.

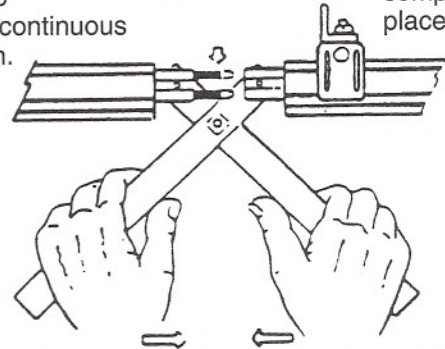

Draw the adjacent conductor bars together with the connector tool. Snap splice cover over completed joint. Proceed to next joint. On laminated bars, a joint keeper is to be installed prior to the splice cover.

Step 4 — Hanger Clamp Tightening and Adjustment (Standard Hangers Only)

Tighten the mounting bolts firmly after aligning the conductor bar in the hanger clamps. Adjust the Clamping Bolts to SLIDING TIGHT as the conductor assembly should be able to slide freely through the hangers and yet be held securely in place.

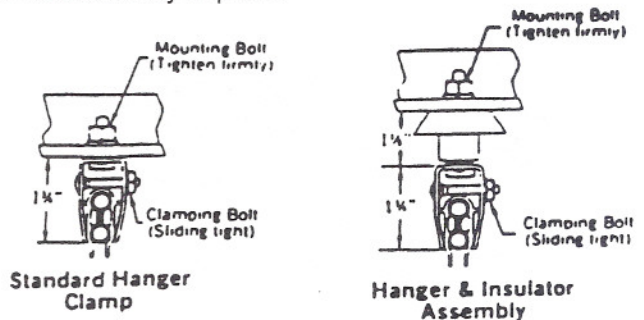

Hanger Clamp	Sliding Tight	Clamping Tight
B-100-2FF	6 Foot Pounds	8 Foot Pounds
B-100-2FFE	4 Foot Pounds	6 Foot Pounds
B-100-2FEA	—	6 Foot Pounds

NOTE: The Clamp hanger permits anchoring at the center of the run. Use the "Clamping Tight" column setting for the anchor point.

Step 5 —Center Power Feed Installation for EFE Model

Cut the conductor insulating cover to accept the connector clamp. Install the ²Connector clamp and the ³power feed-in cable. Place the power feed in insulating case ⁴halves around the connector clamp and ⁵secure with the two spring clips.

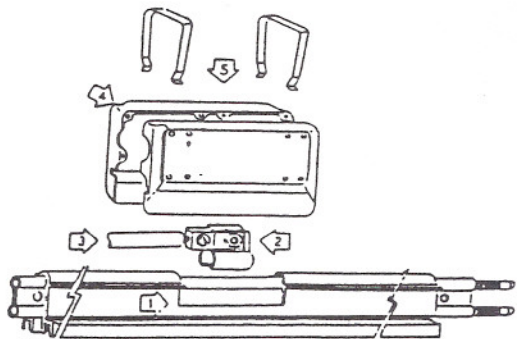

Center power feeds cannot be installed at the joint location on EFT type cover as it will not provide a continuous track for the flap.

Step 6 — Enclosure Flap Installation

The continuous flap material is shipped either on 500 ft. spools or cut lengths to match the conductor runs ordered. Check for the correct length for cut pieces. The flap can be pressed into the cover slot with finger pressure or a narrow piece of sheet metal (16ga.). Make sure the angle of the flap is to the center of the bar so the two pieces touch when installed. After the flap is installed, insert the EFE-908-GCT end cap into the end of the conductor and tap into the bar with a mallet.

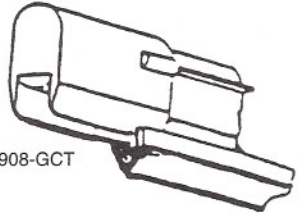
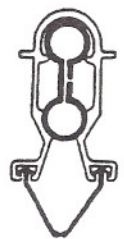

EFE-908-GCT

The end cap is designed to hold the flap in place and to keep from sliding out at the end of the cover.

bar ends must be drilled with 19/64" drill to accept cap stud.

Step 7 — Collector Installation

Because of the special shoe height, the distance from the centerline of the collector mounting post to the conductor surface should be a minimum of 4-1/2 inches. Spacing between collectors is the same as standard units. Three inches is recommended. See Figure 8 Installation Instructions.

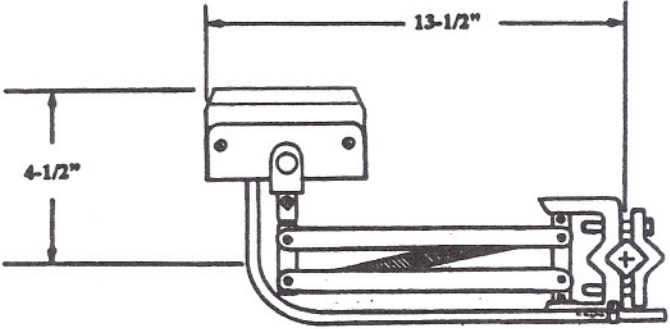

EP-100-V5X

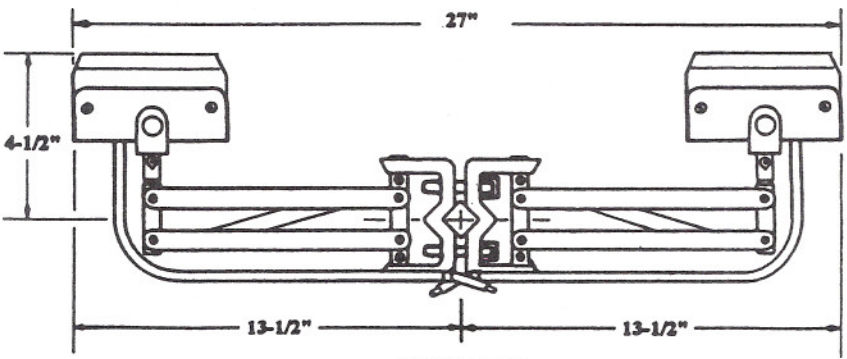

EP-200-VT5X

After mounting the collectors on the mounting post or tow bar, be sure they are directly beneath the respective conductors. Spread the vinyl flap and insert the collector head in the conductor slot. Make sure the shoe has total contact with the conductor.

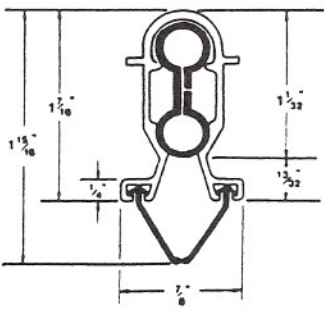

EFE CONDUCTOR DIMENSIONS

Note that the dimensions for the standard cover and the sun cover are the same.