



1351 W. Second Street  
 Oconomowoc, WI 53066  
 Phone: 262-567-2288; 800-434-0062  
 Fax: 262-567-0857  
 E-mail: sales@ductowire.com

1445 Norjohn Ct., Unit 10  
 Burlington, ON L7L 0E6  
 Phone: 905-331-2612; 800-361-WIRE (9473)  
 Fax: 905-331-6639; 800-663-0933  
 E-mail: dow@ductowire.ca

## COLLECTOR REPLACEMENT PARTS

### C-SERIES COLLECTORS

#### COMPLETE HEADS (SHOE, HOLDER, CLEVIS)

40 AMP - #C-40-ABC3  
 100 AMP - #C-100-ABC5

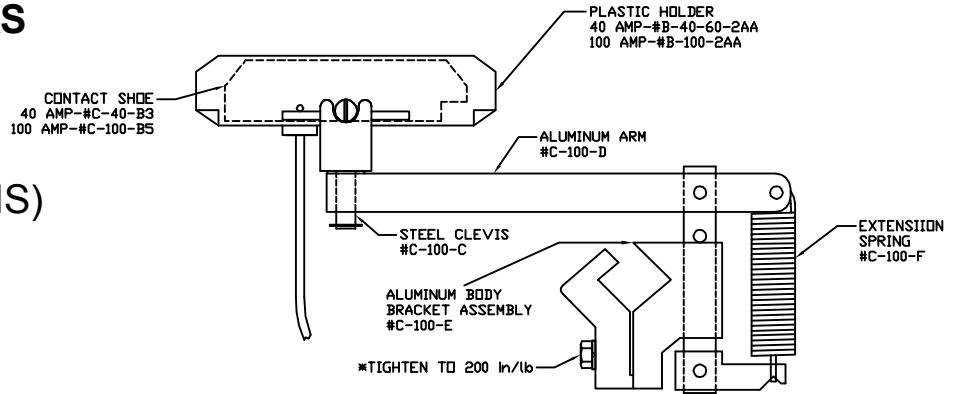

### P-SERIES COLLECTORS

#### COMPLETE HEADS (SHOE, HOLDER, CLEVIS)

40 AMP - #P-40-ABC3  
 100 AMP - #P-100-ABC5

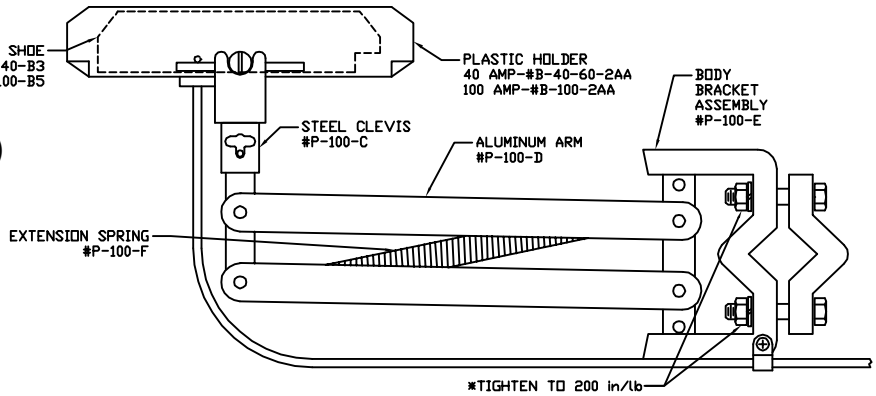

### B-SERIES COLLECTORS (OBSOLETE DESIGN)

#### COMPLETE HEADS SAME AS C-SERIES

#### COMPLETE COLLECTORS

40 AMP - #B-402SC3  
 40 AMP - #B-40-2LC3  
 100 AMP - #B-100-2SC5  
 100 AMP - #B-100-2LC5

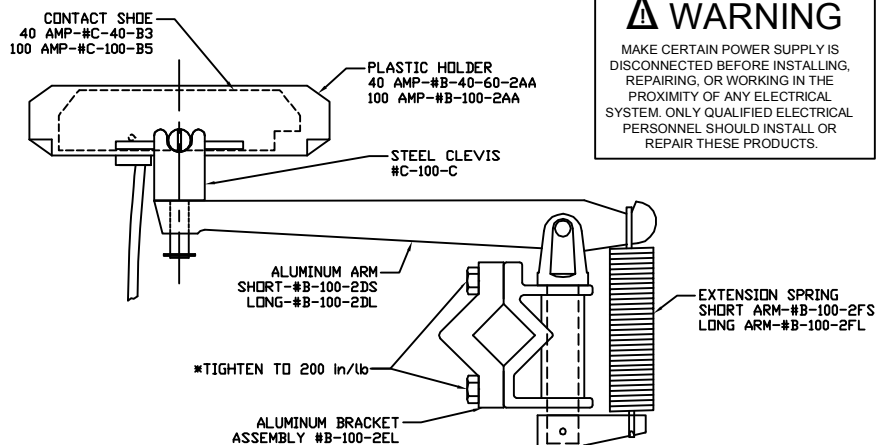

**⚠ WARNING**  
 MAKE CERTAIN POWER SUPPLY IS DISCONNECTED BEFORE INSTALLING, REPAIRING, OR WORKING IN THE PROXIMITY OF ANY ELECTRICAL SYSTEM. ONLY QUALIFIED ELECTRICAL PERSONNEL SHOULD INSTALL OR REPAIR THESE PRODUCTS.

\*SEE OVERLEAF FOR OBSOLETE PARTS

Duct-O-Wire® Company reserves the right to alter or amend technical specifications at any time without notice.

# B-SERIES COLLECTORS (OBSOLETE DESIGN)

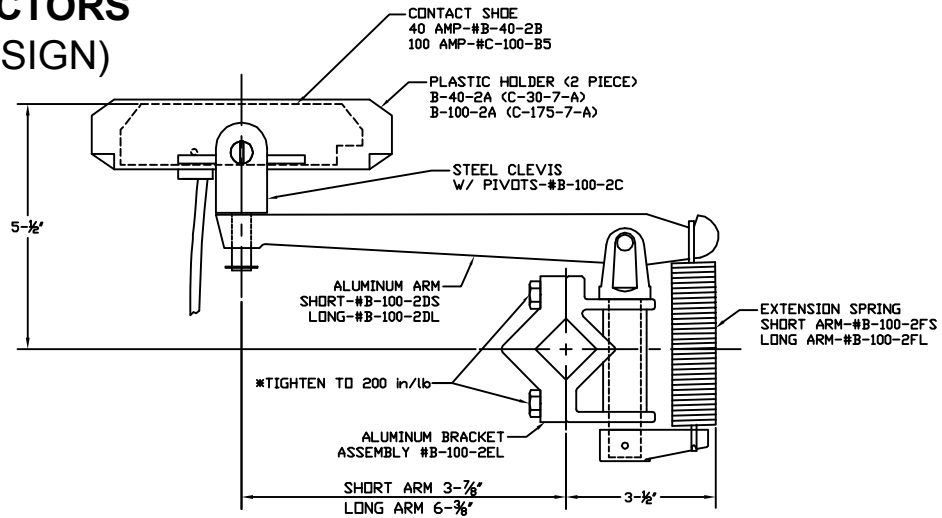

**NOTE:** Some older systems require  $\frac{3}{16}$ " wide contact shoes. The following items should be ordered:  
 30 AMP CONTACT SHOE - #B-30-2B  
 75 AMP CONTACT SHOE - #B-75-2B  
 PLASTIC HOLDER FOR B-30-2B (2 PIECE) - #B-30-2A  
 PLASTIC HOLDER FOR B-75-2B (2 PIECE) - #B-75-2A

# COLLECTOR CONTACT SHOES (B, C & P-SERIES COLLECTORS)

## CURRENT DESIGN (GROOVED CONTACT SURFACE)

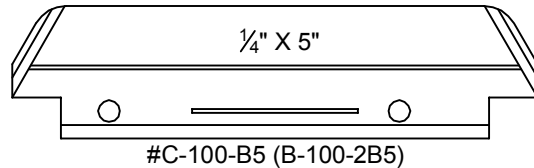
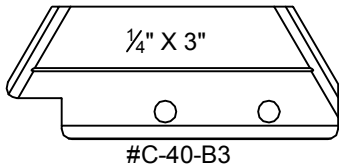

## OBSOLETE DESIGN (GROOVED CONTACT SURFACE)

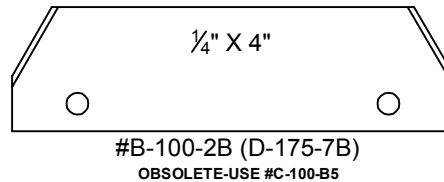
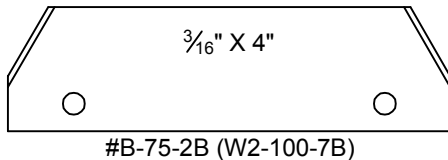
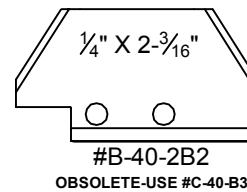
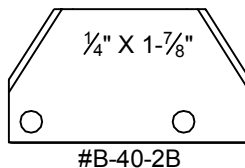
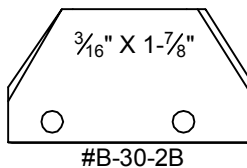

# MAINTENANCE PARTS

**CATALOG NO.**  
B-100-2ACT

**CLEANING HEAD ASSEMBLY-**

Consists of two piece holder, steel clevis, and stainless steel wire cleaning brush  
(May adapt to existing B-Series or C-Series Collector Arms)

**NOTE:** Additional collector required with contact shoe to maintain power.

C-100-LCT

**COMPLETE COLLECTOR ASSEMBLY (C-SERIES) WITH . . .**  
. . . Cleaning Brush in lieu of Contact Brush.

C-100-CT

Cleaning Brush-Stainless Steel Bristle.

C-40-B3-SC

3" Cleaning Shoe with Carborundum Insert.

C-100-B5-SC

5" Cleaning Shoe with Carborundum Insert.

**⚠ WARNING**

MAKE CERTAIN POWER SUPPLY IS DISCONNECTED BEFORE INSTALLING, REPAIRING, OR WORKING IN THE PROXIMITY OF ANY ELECTRICAL SYSTEM. ONLY QUALIFIED ELECTRICAL PERSONNEL SHOULD INSTALL OR REPAIR THESE PRODUCTS.