



Duct-O-Wire® CAS-1RA-O Addendum

Collision Avoidance and Reflector Array Kit Instructions

EFFECTIVE NOVEMBER 2013

Your Duct-O-Wire CAS-1RA-O Collision Avoidance Kit comes complete with (1) Sensor Unit, (1) Sensor Unit mounting bracket and hardware, (1) Plug, (1) Bushing, (2) Grommets, (1) Reflector Array and (1) Instruction sheet.

MAKE CERTAIN POWER SUPPLY IS DISCONNECTED BEFORE INSTALLING, REPAIRING, OR MAKING ADJUSTMENTS TO THIS DEVICE. THIS DEVICE SHOULD BE INSTALLED BY QUALIFIED ELECTRICAL PERSONNEL ONLY.

THIS PRODUCT IS DESIGNED FOR OPERATING DISTANCES OF 30 FEET MAXIMUM AND THREE FEET MINIMUM. DO NOT EXCEED THESE DISTANCES.

SENSOR RATING: 3 AMPS MAX

1. When mounting the sensor to the bracket, make sure the screw heads are on the bracket side and the nuts are captive inside the sensor. Do not over tighten the sensor mounting screws.
2. Wire the sensor with a round cable, properly rated for voltage and application. The rubber bushing must fit tightly around the cable. Always use the provided plug to seal the remaining entrance. As with all sensors of this type, it is important to keep dust, moisture and contaminants from the inside of the unit. **The hole size for the cable entry into the sensor unit has been reduced from previous versions. It is necessary to slide the compression nut and the rubber bushing onto the cable prior to stripping back the outer jacket for wiring. After wiring, fully tighten compression nut prior to reassembling.**

CAS-1 WIRING DIAGRAM

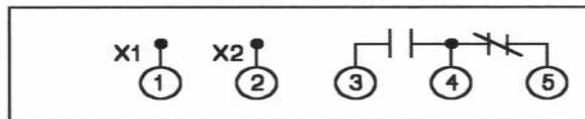

3. This sensor operates on either 24-240 VDC or 24-240VAC. Connect power leads to terminals 1 and 2.
4. Terminals 4 and 5 are normally closed and are the ones generally used for Collision Avoidance applications. They should be wired in series with the direction circuit to be interrupted.
5. Mount the reflector array securely to a solid object. **The reflector array must be centered and aligned both horizontally and vertically on the same plane as the sensor unit.** (see diagram)
6. To adjust the trigger point: (A) With the crane positioned at the trigger point, move the sensor unit so that the visible red light spot is just to the left or right of the reflector array. (B) Slowly move the sensor unit towards the center of the reflector array until the indicator light on the sensor switches on. The visible red light spot will be at the edge of the reflector array. (C) Secure the sensor unit in this position. (D) Check the switching action by moving closer to and further away from the trigger zone. (E) Slight adjustment of the sensor unit may be necessary to attain desired switching point.
7. Do not adjust the sensitivity on the sensor unit. It must remain in the factory set, full clockwise, maximum gain position.
8. If multiple photoelectric units are being used in the same proximity, installation locations must be far enough apart that there is no chance that one sensor will intercept the light beam from another unit.
9. As with all photoelectric sensors, it is necessary to keep excessive dust or dirt from diminishing the optical effectiveness of the device. Wiping the sensor's optical surface and the reflector array occasionally with a moist, not wet, cloth should be made part of a normal maintenance procedure.

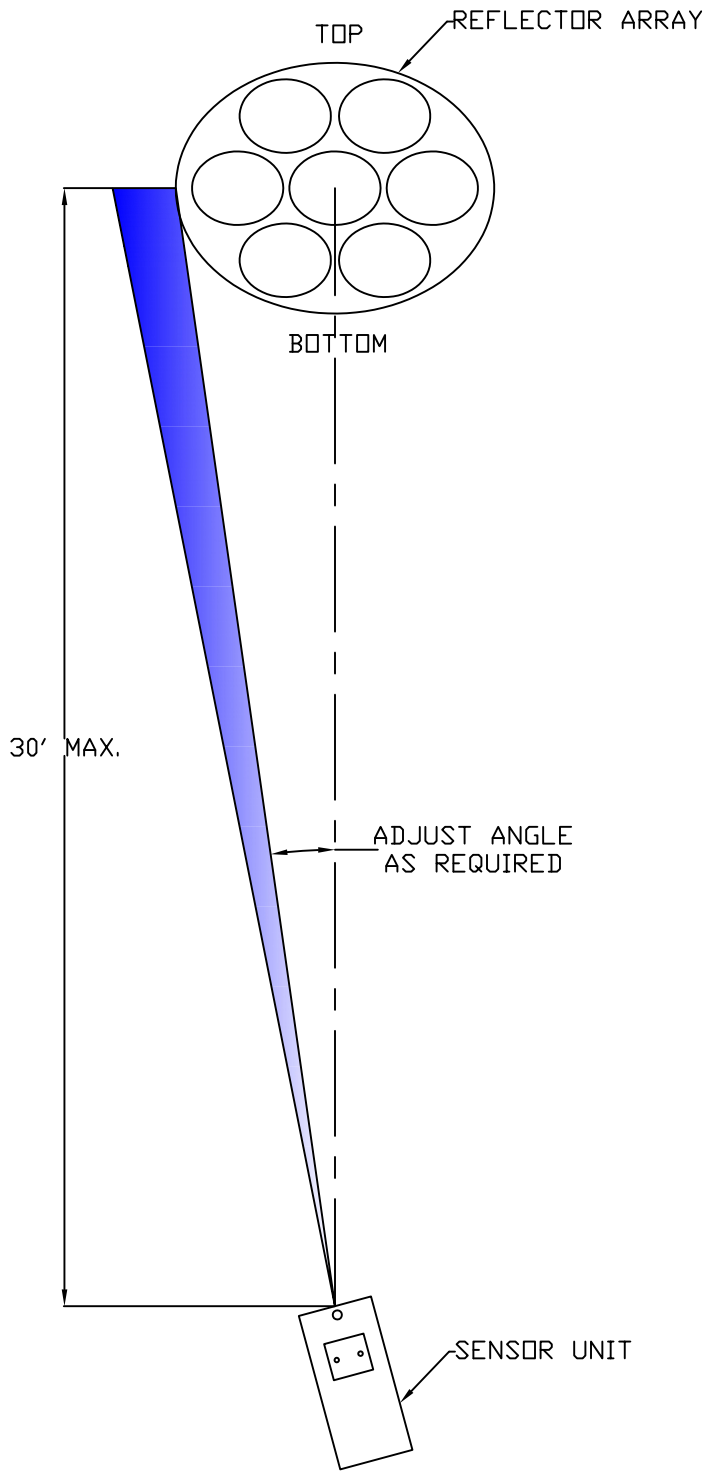

TOP VIEW

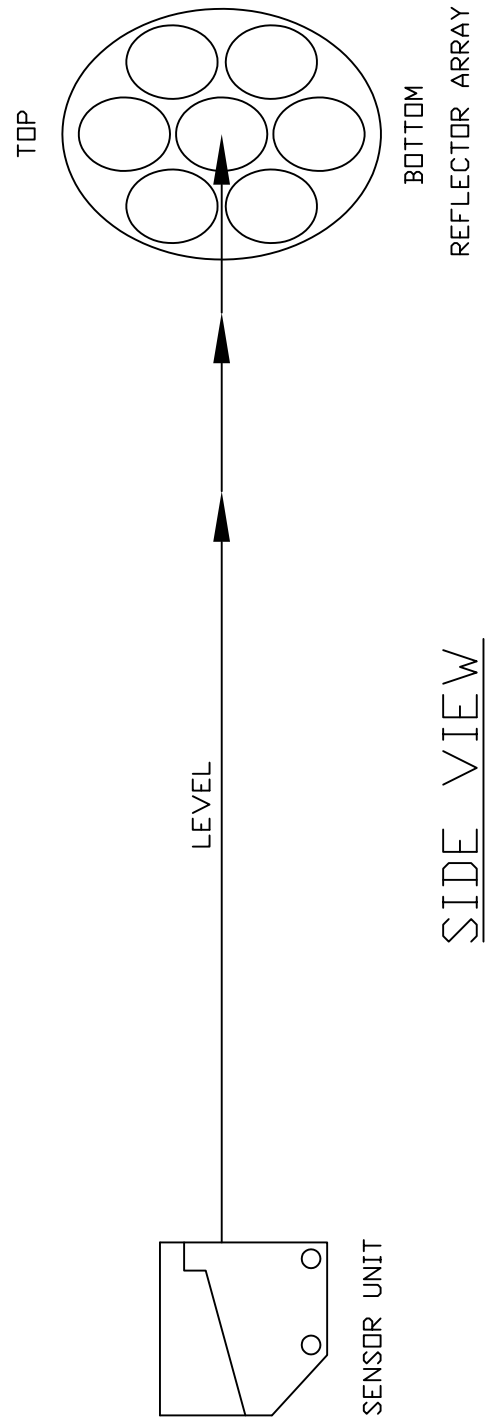

SIDE VIEW

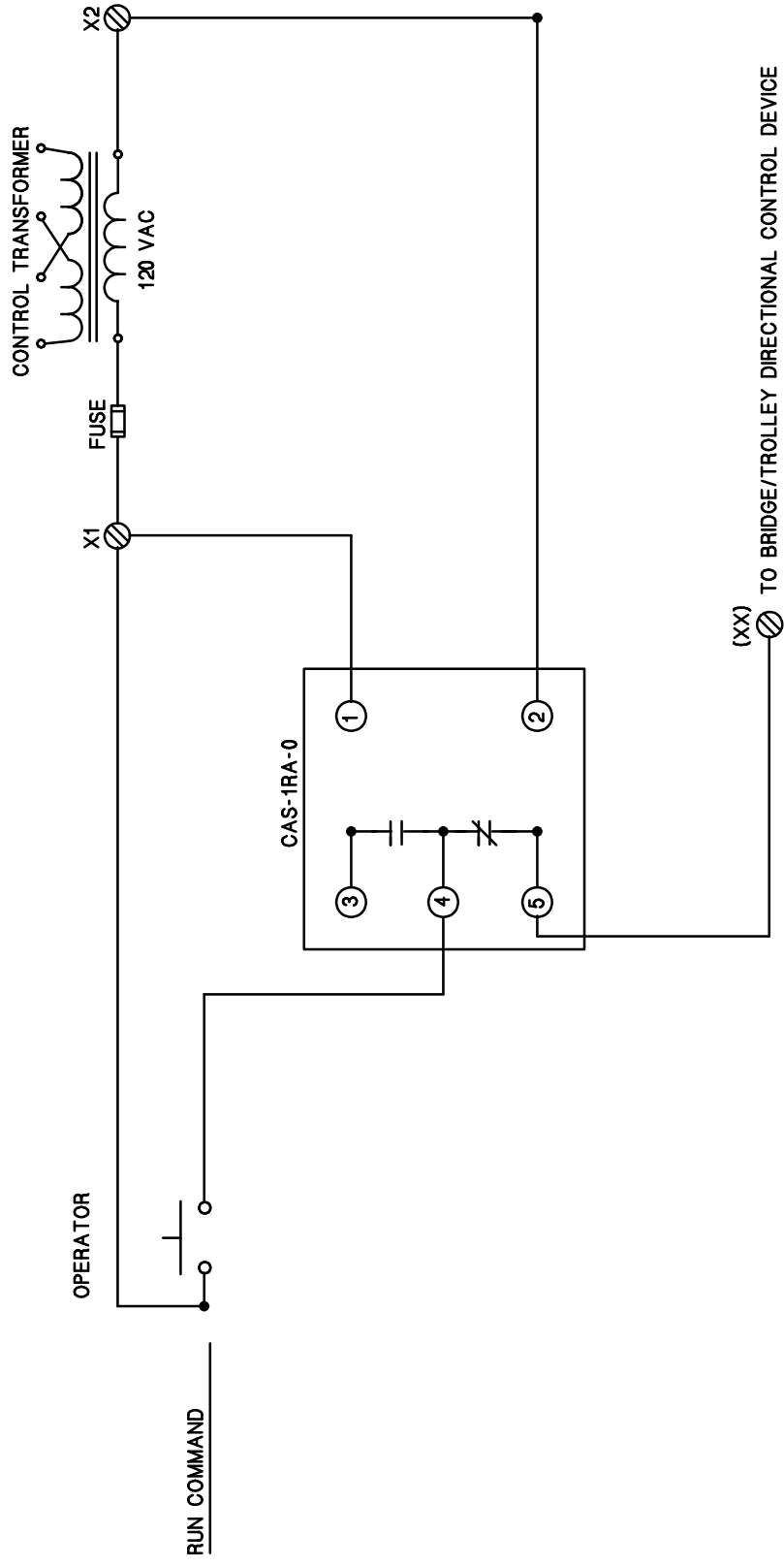

DUCT O WIRE COMPANY	
CAS-1RA 0 Collision Avoidance	
Directional Run Command Interruption/Travel Stop	
Drawing # CAS1RAO	Drawn By: R Peterson Date: 10/28/13



1351 W. Second Street
Oconomowoc, WI 53066
Phone: 262-567-2288; 800-434-0062
Fax: 262-567-0857
E-mail: sales@ductowire.com

1445 Norjohn Ct. Unit 10
Burlington, Ontario, Canada L7L 0E6
Phone: 905-331-2612; 800-361-WIRE (9473)
Fax: 905-331-6639; 800-663-0933
E-mail: dow@ductowire.ca
