

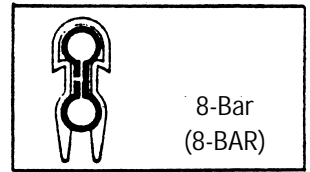

1351 W. Second Street
 Oconomowoc, WI 53066
 Phone: 262-567-2288; 800-434-0062
 Fax: 262-567-0857
 E-mail: sales@ductowire.com

1445 Norjohn Ct. Unit 10
 Burlington, Ontario, Canada L7L 0E6
 Phone: 905-331-2612; 800-361-WIRE (9473)
 Fax: 905-331-6639; 800-663-0933
 E-mail: dow@ductowire.ca

INSTALLATION INSTRUCTIONS • DUCT-O-BAR



I. TYPICAL INSTALLATIONS: A. Standard Vertical Mounted Conductors (3-Phase System — Bottom Contact)

5 Ft. Maximum Support Spacing

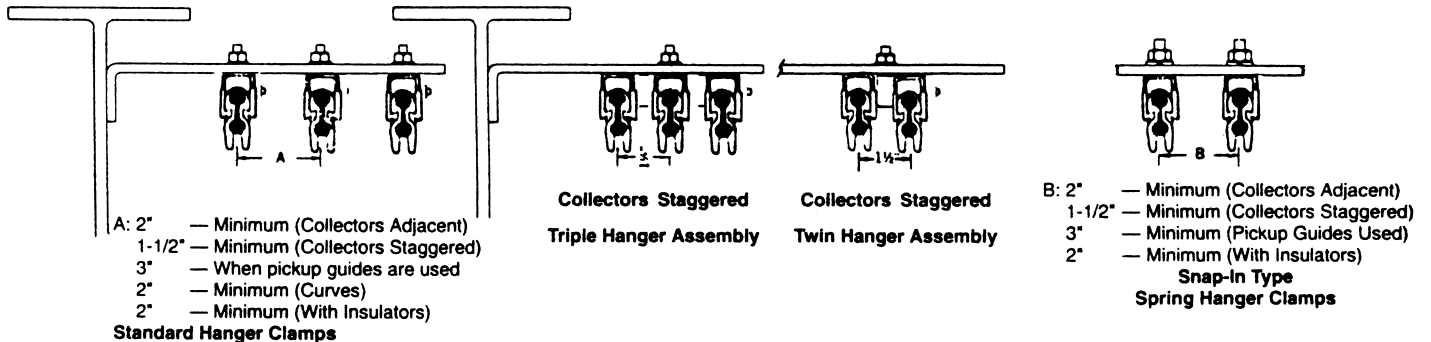

B. Lateral Mounted Conductors

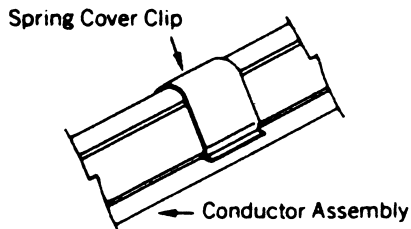
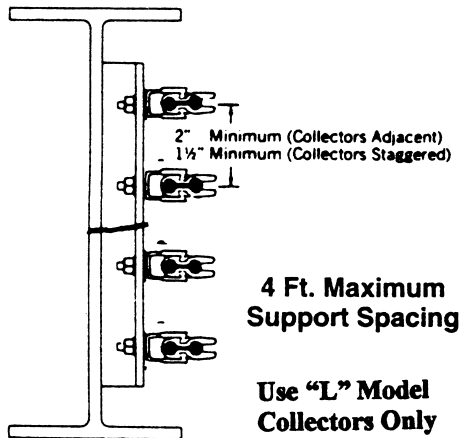

- NOTES:** 1) Spring cover clips are located at mid-span between each pair of hanger clamps on lateral mounted systems.
- 2) Spring type hanger clamps may also be used as shown.

C. Monorail Application

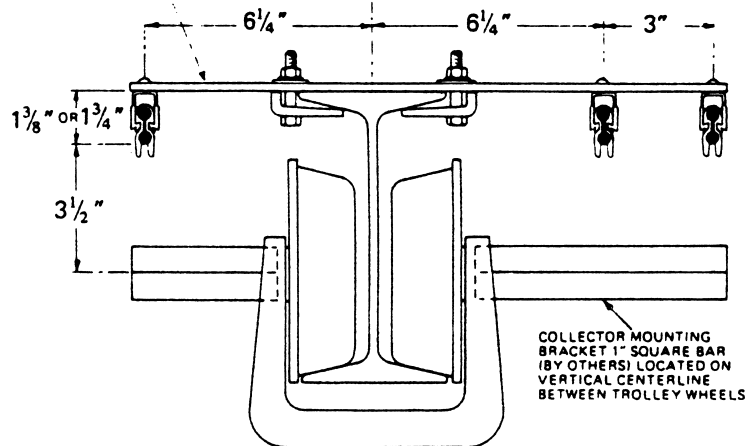

- NOTES:** 1) Spring type hanger clamps may also be used as shown except on curves and runs less than 30 ft. long.
- 2) Install two conductors on one side of the beam and one conductor on the opposite side to balance the collector spring forces, particularly on light weight hoists.

CAUTION

MAKE CERTAIN POWER SUPPLY IS DISCONNECTED BEFORE INSTALLING, REPAIRING, OR WORKING IN THE PROXIMITY OF ANY ELECTRICAL SYSTEM. ONLY QUALIFIED ELECTRICAL PERSONNEL SHOULD INSTALL OR REPAIR THESE PRODUCTS.

Steel Snap-In Hanger Clamps

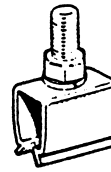
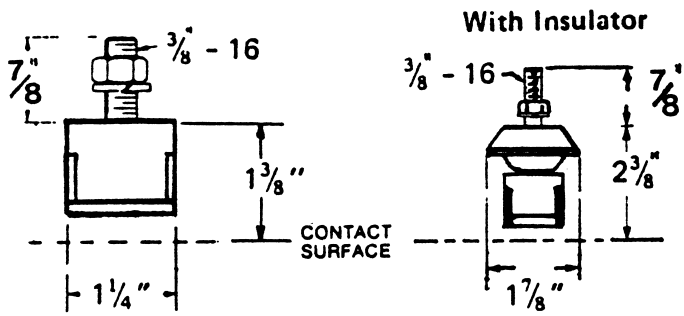

8-908-2SF

TIGHTEN TO 150 in-lb

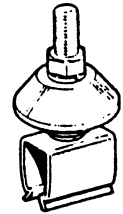

8-908-2SFG

TIGHTEN TO 150 in-lb

Plastic Snap-In Hanger Clamps

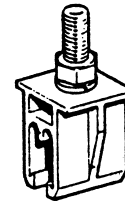
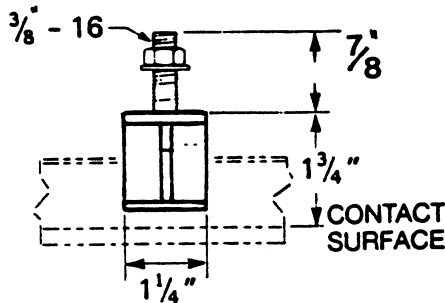

8-908-2PF

TIGHTEN TO 100 in-lb

IV. EXPANSION GAP AND ANCHORING REQUIREMENTS

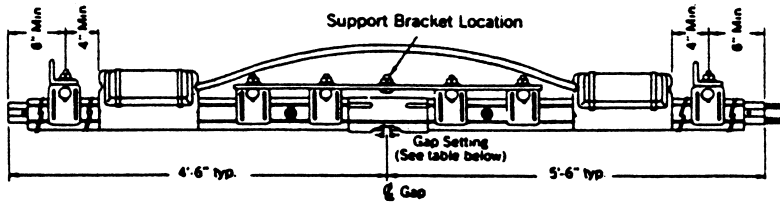

STEEL EXPANDS 1"/100°F/150 ft.
COPPER EXPANDS 1"/100°F/100 ft.

Expansion gaps should be placed at intervals determined by the temperature rise of the specific conductor, i.e. if the estimated temperature rise for a steel conductor system is 100°F, provisions should be made for expansion gaps at midspan for systems 300 ft. to 600 ft. in length. Beyond 600 ft. the expansion gaps should be placed according to the following table.

Steel Conductors - Every 300 ft. of straight run.
 Copper Conductors - Every 200 ft. of straight run.
 All Systems - At building expansion joints.

ANCHORS

Anchor clamps are required at midpoint on all systems without expansion gaps. Systems with expansion gaps require an anchor point midspan between expansion gap and each end of the runway. When 2 or more expansion gaps are used, anchor points must also be placed midpoint between gaps. The use of an anchor clamp set permits controlled expansion toward the expansion gap at the end of the run.
 (Specify part no. B100-2FEA)

EXPANSION GAP INSTALLATION

A 10' Expansion Gap Assembly is installed in the same manner as other 10' sections of conductor bar. The connector pins have been left off and attached to the lead wire in a bag. This will allow you to position the expansion gap assembly in the proper direction to match the support location with your mounting bracket. It is critical that the expansion gap is mounted as shown in the above picture to secure the assembly and allow the bar to expand as designed. For shipping purposes, the gap has been completely closed and must be adjusted accordingly to the ambient temperature during installation. Set the gap according to the table below. Install the anchor clamps (also attached to the expansion gap) as shown on the enclosed supplementary installation instructions. Recheck the gap setting after installation of conductor bars.

OPERATING TEMPERATURES

GAP SETTING

Min.	Max.	Ambient Temperature	Gap Width
0	100°F	25°F	1-1/2"
		50°F	1"
		75°F	1/2"
25°F	125°F	50°F	1-1/2"
		75°F	1"
		100°F	1/2"
50°F	150°F	75°F	1-1/2"
		100°F	1"
		125°F	1/2"

INSTALLATION DIMENSIONS — COLLECTORS

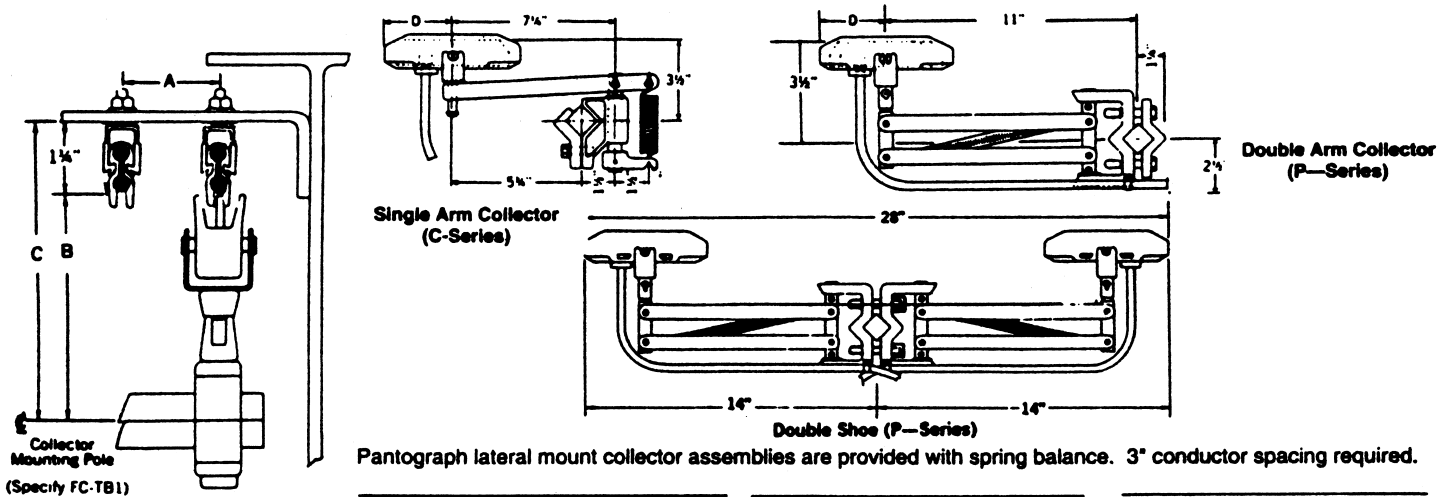

DIMENSION A (MINIMUM)		DIMENSION		B C		DIMENSION D	
2"	— Minimum collectors are adjacent	B	Series Collectors	5-1/2"	7-1/4"	40 AMP Collectors	2"
1-1/2"	— Minimum collectors are staggered	P	Series Collectors	3-1/2"	5-1/4"	100 AMP Collectors	3"
3" or 4"	— When pickup guides are used	C	Series Collectors	3-1/2"	5-1/4"		
2"	— When insulators are used						

Joining Conductor Bar Sections

Draw the adjacent conductor bars together with the connector tool. Snap splice cover over completed joint. Proceed to the next joint.

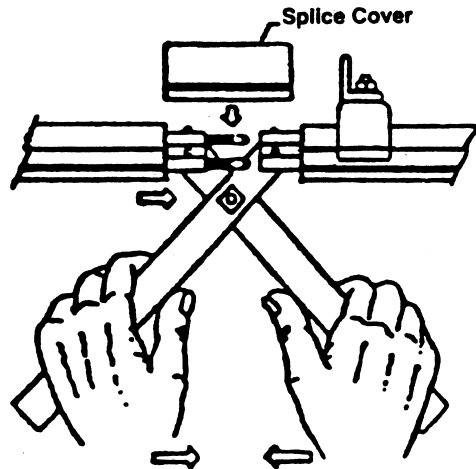

8-A Anchor Clamp

8-A Anchor Clamp

The use of two 8-A anchor clamps as shown in the following illustration provides positive anchoring for the conductor. This will prevent conductors from sliding out of position in systems which use spring type hangers. In systems with expansion gap assemblies anchors are used to keep the gap settings in calibration. Follow the instructions which come with the expansion gap assemblies.

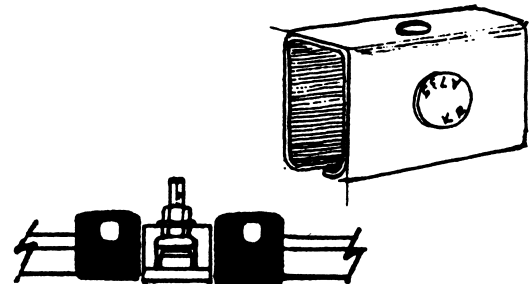

Clamping pair eliminates movement in either direction.

Power Feed Installation

(1) Locate at conductor joint or notch the conductor insulating cover to accept the connector clamp. (2) Install the Connector clamp and (3) the power feed-in cable. (4) Place the power feed insulating case halves around the connector clamp and (5) secure with the two spring clips.

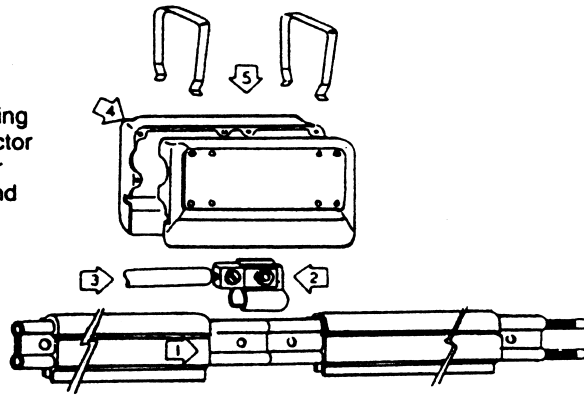

End Cap Installation

Cut off the exposed ends of all conductors flush with the cover and install the end cap all the way on.

INTERLOCKS, SWITCHES, OR FIXED GAPS

For fixed gaps occurring at interlocks, the maximum gap is 1". By using transfer caps, the collector brushes are able to transfer evenly and smoothly. Round both ends of collector brush to ensure a smooth transfer. 100 AMP P-series collectors are recommended to properly bridge the gap without loss of power.

TRANSFER CAP

The transfer cap is installed in lieu of end cap at all switches, interlocks and discontinuous circuits with pickup guides.

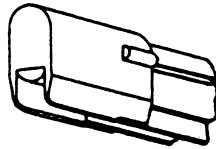

General Comments — Final Inspection

In either type of mounting, sight down the installed conductors and straighten any chance bends or misalignment. **Make sure that the hanger clamps are not drawn too tightly.**

Check to be sure that the collector shoe passes freely around the cover, and that the collector brush passes freely between the lips of the cover without rubbing, and that makes good contact with the conductor bar.

SPRAY PAINTING

If at all possible, all spray painting of the surroundings should be done prior to installation of the DUCT-O-BAR run. If spray painting must be done after the installation has been made, **extreme care** must be taken, by the use of masks, tape or similar methods, to protect the **contact surfaces** of the conductors. Paint on these surfaces will **cause serious inoperative difficulties.**

HEAT

Standard DUCT-O-BAR Vinyl Cover is not meant to be used in high heat areas. The standard cover will not support combustion, but will start to flow at 160°F. A special High Temperature Vinyl Cover is recommended when surface heat exceeds 150°F. Consult the factory.