



1351 W. Second Street
 Oconomowoc, WI 53066
 Phone: 262-567-2288; 800-434-0062
 Fax: 262-567-0857
 E-mail: sales@ductowire.com

1445 Norjohn Ct. Unit 10
 Burlington, Ontario, Canada L7L 0E6
 Phone: 905-331-2612; 800-361-WIRE (9473)
 Fax: 905-331-6639; 800-663-0933
 E-mail: dow@ductowire.ca

HD-1000-3 & HD-1500-3 INSTRUCTIONS FOR INSTALLATION

PLEASE READ CAREFULLY BEFORE STARTING INSTALLATION

CAUTION

MAKE CERTAIN POWER SUPPLY IS DISCONNECTED BEFORE INSTALLING, REPAIRING, OR WORKING IN THE PROXIMITY OF ANY ELECTRICAL SYSTEM. ONLY QUALIFIED ELECTRICAL PERSONNEL SHOULD INSTALL OR REPAIR THESE PRODUCTS.

PRELIMINARY

Check all materials to be sure that the proper number of brackets, hanger clamp assemblies, bolted joint assemblies, joint covers, power feeds, end caps, collectors, expansion gap assemblies, (when needed) isolating sections, (when needed) anchor clamp sets, and proper quantity of conductor bar assemblies have been received.

SPRAY PAINTING

Spray painting should be done prior to the installation of the Duct-O-Bar runway. If spray painting is done after installation extreme care should be taken to protect the contact surface of the conductors with the use of masking materials. Paint on these surfaces will cause serious operational difficulties.

SYSTEM LAYOUT

For systems under 300 ft. in runway length there are usually no expansion gap assemblies required and you may skip the instructions for that step. For those systems that are longer IT IS IMPORTANT THAT THE HANGER BRACKET INSTRUCTIONS ARE FOLLOWED CLOSELY.

Using the following schematic diagram as a guide, make a simple system drawing and mark the appropriate locations of the brackets, power feeds, and expansions gap assemblies (when used) and the anchor locations. Now you are ready to start.

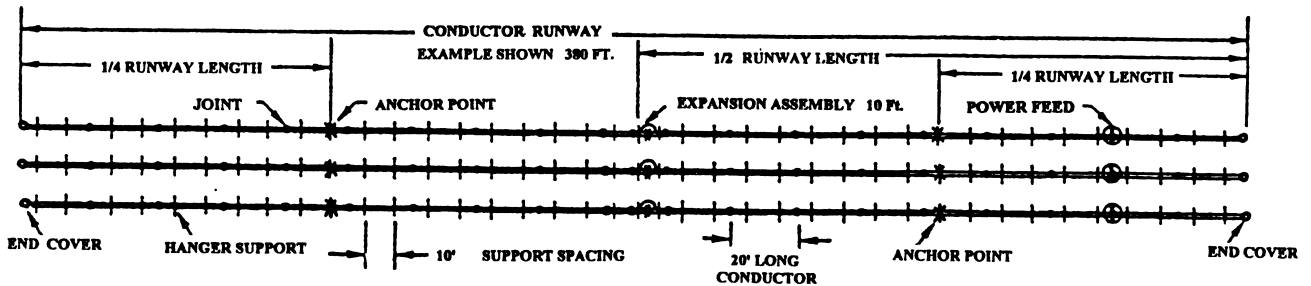

STEP 1. HANGER CLAMP BRACKET INSTALLATION

Starting at one end of the runway, place a mark for the first bracket at least 12 inches in from the end. Sight in the remaining brackets every 10 feet after the first one except when expansion gap assemblies are used. At the point where an expansion gap is used it will be necessary to check the expansion gap assembly so that the bracket will miss the gap and jumper wires.

STEP 2. HANGER CLAMP INSTALLATION

Fasten the hanger clamps to the brackets, leaving the nuts finger tight. When the hanger clamps are in place it is necessary to slide the conductors into the hanger clamps until the conductors meet. Then tighten and adjust the hanger clamps. See Steps 3 & 4.

SCHEMATIC DIAGRAM



HD-1000-2F
Hanger

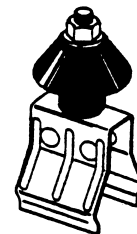

HD-1000-2FG
Hanger w/Insulator

ANGLE BRACKET SUPPORT

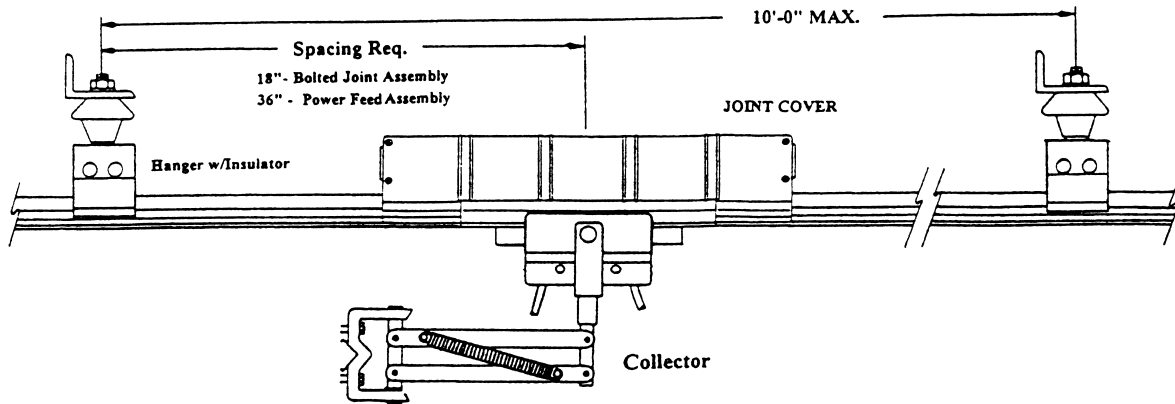

TYPICAL SYSTEM INSTALLATION

Bracket & Hanger Spacing

Use these illustrations for positioning the brackets, hangers, and collectors. Note the 6-1/2" spacing from the 1" square collector mounting post to the contact surface of the conductor. The spacing of the brackets and hangers near joints and power feed locations shows that more room is needed for wire leads coming from the power feed covers and covers on the expansion gap jumpers.

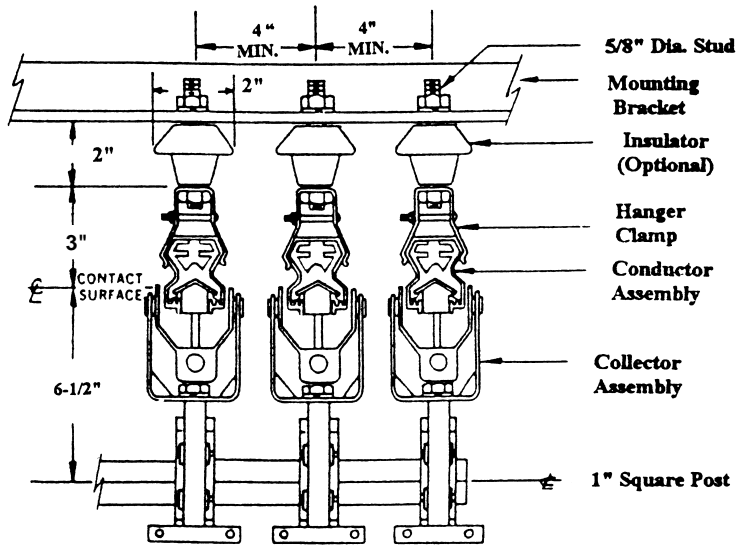

STEP 3. BOLTED JOINT CONNECTION

Before joining the conductor bars, be sure the surfaces are clean of any oxide that may have formed during shipment or storage. Clean with a wire brush and apply the electrical joint compound where contact is made between joints and conductors. When joining the conductors with the bolted joint assembly be sure to align the bolt heads so they slide into the groove of the conductor. Place the two piece joint cover over the bolted joint, install the 4 cover screws and the 4 spring clips.

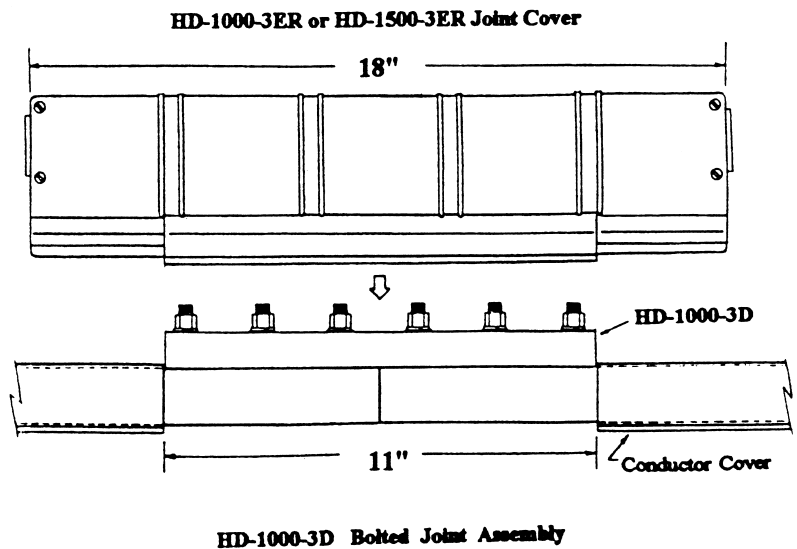

STEP 4. POWER FEED INSTALLATION

Install the power feed at a predetermined location on the runway. Use the same procedure as the bolted joint assembly applying joint compound between the pieces of the wire terminal block and the conductor bar. Slide the power feed assembly into the conductor ends as with a bolted joint. Tighten all bolts for a firm fit.

Note the cable hole sizes for the HD-1000 and HD-1500 vary between the 350 MCM and 500 MCM cables. Open the knockouts at the end of the joint cover so that it will fit over the cable. Then install the cover screws and spring clips.

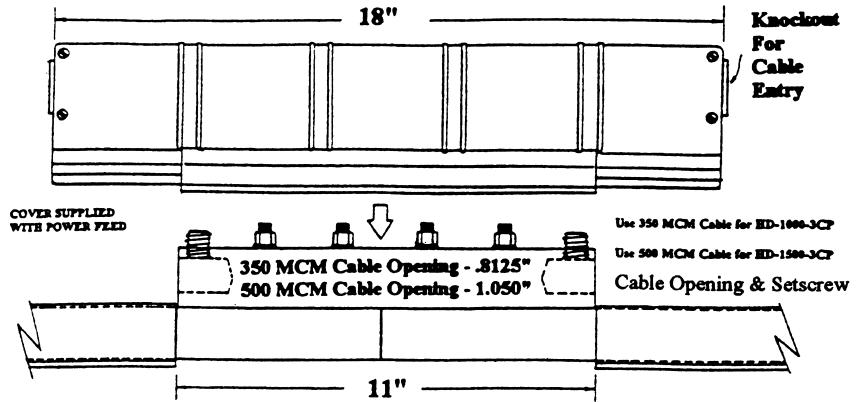

**HD-1000-3CP and HD-1500-3CP
Center Power Feed & Cover Assembly**

STEP 5. EXPANSION GAP ASSEMBLY

Expansion gap sections should be placed at intervals determined by the ambient temperature change at the conductor location and the length of the runway. For long runways, a standard indoor system would have an expansion gap every 300 ft. and at building expansion joints. An outdoor system would be affected by a much wider temperature variation and would have more expansion joints. A method of calculating expansion gap requirements is shown in the HD conductor brochure.

Anchor. There must be one or more anchor points in a properly estimated and installed conductor system. For a system with no expansion gap assemblies, install a single anchor hanger in the center of each conductor run. With one expansion gap, an anchor is placed half-way between the gap and each end of the system. See the Anchor Installation sheet.

It is important that the gaps be properly set during installation. The maximum gap opening in the HD-1000 and HD-1500 amp system sizes is 3.25". Set the gaps as follows:

1. Determine the operating range that the system will experience during the entire calendar year. For an indoor location it may be from 55 degrees F., in Winter to 95 deg. F. in Summer. This would be a 40 deg. F. operating range.
2. At installation the ambient temperature measured 65 deg. F. Since the gap is wide open at the lowest operating temperature the gap should be set at a fraction of the full opening determined by the ambient temperature in relation to the operating span. In this example the temperature at the installation is 95-65 or 30 degrees from the top of the 40 deg. operating temperature or 30/40 of the 3.25" opening. Set the gap at 3/4 of 3.25" or 2.4"

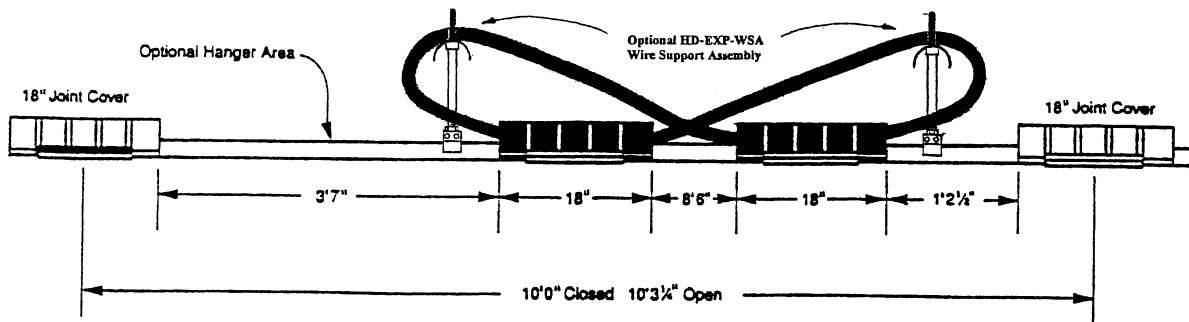

HD-1000-3H10 & HD-1500-3H10

STEP 6. COLLECTOR INSTALLATION

Using the dimensions shown in the following drawings, position the 1" square post 6-1/2" from the tracking surface of the conductor bar. Make sure that the collectors are spaced just below the center of each conductor.

tor run. The collectors will articulate to handle imperfections in the runway but a continuous tracking to one side of the conductor will cause uneven shoe wear.

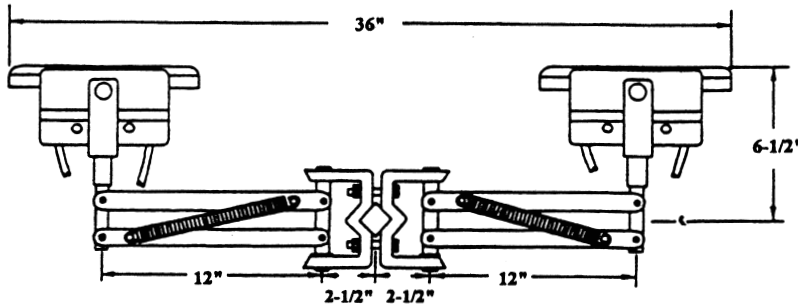

HD-600-TPC 600 AMP TANDEM COLLECTOR

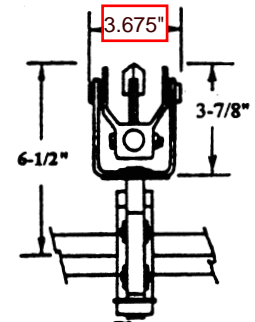

Voltage Drop Calculations - A.C. & D.C.

$$\text{A.C. } V = I \times L \times 1.73 \times Z$$

$$\text{D.C. } V = I \times L \times 2 \times R$$

where V = volts lost

I = load current (amperes)

L = length of runway from power feed

Z = a.c impedance

R = d.c. resistance

System Parameters	1000 Amp System	1500 Amp System
Current Rating (Continuous test sample)	1000 amps	1500 amps
Weight of conductor (lbs./ft.)	1.65	2.19
A.C. impedance (ohms/ft.) @ 4" spacing	.000040	.000030
D.C. resistance (ohms/ft.)	.000014	.000009

STEP 7. END CAP INSTALLATION

On both ends of each conductor run it is necessary to install an insulated end cap. CUT THE EXPOSED END of the conductor bar back to the insulated cover.

Then install the black plastic end cap over the conductor cover and push the end cap on until it butts up completely to the end of the conductor.

STEP 8. FINAL INSPECTION

After all installation work is complete, sight down the conductors and make sure all hangers have been tightened properly to allow for a sliding fit. Also make sure the anchors are positioned and tightened. Recheck the expansion gap settings for proper gap width based upon the ambient temperature. Make sure all joint covers, power feed covers, and end caps

are in place and properly installed. When installation is complete, run the unit down the runway to make sure that collectors track properly through all joints and expansion gaps. Recheck the end caps and make sure excess conductor is trimmed.

SPECIAL SYSTEMS

Systems with isolating sections or heater cables for ice prevention require special quotations. There will be additional installation information provided for those systems.

FIELD CUT

Duct-O-Wire recommends that all conductor bar be field cut immediately beyond required collector travel or a maximum of 12" past the last support bracket. Be sure that conductor bars are clear of any other electrical power lines by at least 9 inches. KEEP ALL CONDUCTOR POWER OFF DURING CONSTRUCTION.